

Operating instructions

for BioFresh NoFrost combined refrigerator-freezers

GB

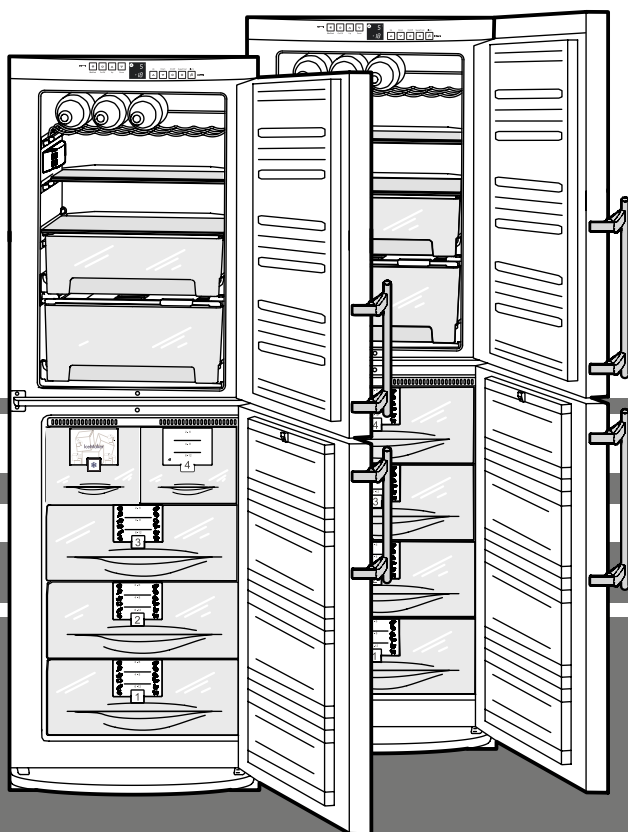

7082 344-01

BN/BNes/SBNes 6 4906

LIEBHERR

The appliance at a glance

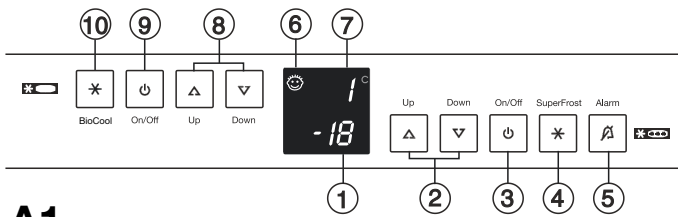

A1

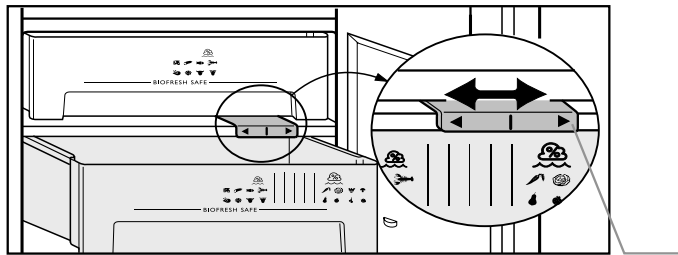

A2

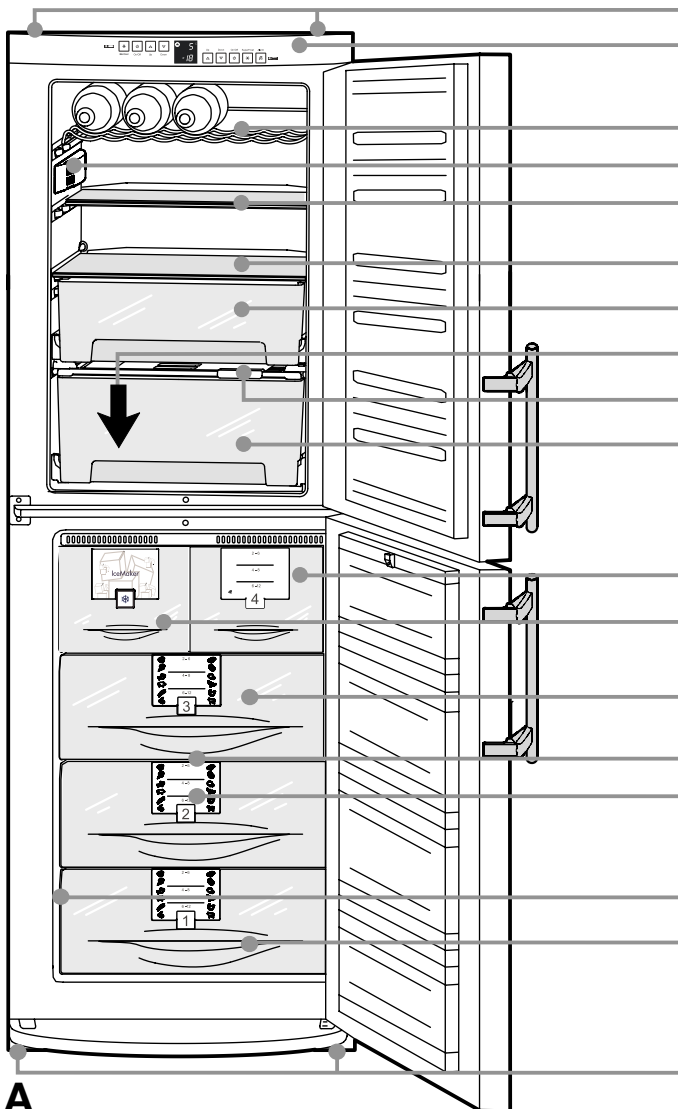

A

Operating and control elements, fig. A1

- Freezer compartment**
- ① Temperature display and setting display with nA FrostControl and power failure display with call-up function for highest temperature
 - ② Temperature setting buttons: Up button = higher, Down = lower, recommended setting: -18°C
 - ③ On/off button
 - ④ SuperFrost button, lit = function activated. For fast freezing of fresh food
 - ⑤ Audible warning on/off button
 - ⑥ Child-proof lock (illuminated symbol = active, BioFresh and freezer compartments are protected against being switched off accidentally)

BioFresh compartment

- ⑦ Temperature display and setting display
- ⑧ Temperature setting buttons: Up button = higher, Down = lower, recommended setting: 1°C
- ⑨ On/off button
- ⑩ BioCool button, lit = function activated. For fast cooling of food in the BioFresh compartment

Humidity setting in **BioFresh** drawer, fig. A2:
slider to left: dry, slider to right: humid

Description of appliance and equipment fig. A

Rear transport grips

Operating and control elements

BioFresh compartment, 0°C to 2°C

Champagne shelf for standard and small sparkling wine bottles

Interior light

Sectioned shelf

Zone with relatively dry climate

Drawer for dry and wrapped food

Defrost water drain

Humidity control

Drawer with adjustable humidity for storing salad, vegetables and fruit in a humid climate

Freezer, approx. -18°C

Drawers with transparent front panel

IceMaker*

Freezer tray*, cold-storage accumulator*

Shelves and drawers can be removed to make space for large items - VarioSpace

Information system*

Type/Data plate, fig. A3

Ice-cube tray*

Adjustable-height feet, front transport grips, transport castors at back

* Depending on model and options

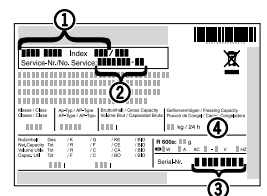

A3

- ① Type designation
- ② Service number
- ③ Appliance number
- ④ Freezing capacity in kg/24 hours

Congratulations on your purchase. In choosing this appliance you have opted for all the benefits of state-of-the-art refrigeration technology, guaranteeing you top quality, a long life span and excellent reliability.

The features on your appliance have been designed to ensure maximum convenience - day in, day out.

This appliance has been manufactured with recyclable materials using an environmentally friendly process, so together you and we are making an active contribution to the preservation of our environment.

To get to know all the benefits of your new appliance, please read the information contained in these operating instructions carefully.

We wish you much pleasure with your new appliance.

Keep these operating instructions in a safe place and pass them on to the next owner, where applicable.

The operating instructions apply to several models. Differences may therefore occur.

Contents

Operating instructions	Page
The appliance at a glance	12
Contents	13
Safety regulations	13
Energy savings	13
Safety instructions and warnings	14
Disposal notes	14
Setting up	14
Connecting to the mains	14
Operation and control elements	15
Switching the appliance on and off	15
Setting the temperature	15
Temperature display	15
Audible warning signal	15
BioCool	16
SuperFrost	16
Power failure/FrostControl display	16
Additional functions	16
Child-proof lock	16
Display brightness	16
Interior light	16
BioFresh compartment	17
Freezer compartment	18-19
Freezing with SuperFrost	18
Notes on freezing and storage	18
Information system	18
Freezer tray	19
Cold-storage accumulators	19
Making ice-cubes	19
Cleaning	19
Troubleshooting	20
Customer service and type plate	20
Instructions for installation and modification	
External dimensions	20
Changing over door hinges	20-21
Insertion into row of kitchen units	21

Safety regulations



- The appliance is designed to cool, freeze and store food and to make ice. It is designed as a household appliance. We cannot guarantee that the appliance will work properly if it is used for another purpose.
- The appliance is set to operate within specific ambient temperature limits according to its climate rating. These temperature limits should not be exceeded. The correct climate rating for your appliance is indicated on the type plate. This is explained as follows:

Climate rating	Set for ambient temperatures of
SN	+10°C to +32°C
N	+16°C to +32°C
ST	+18°C to +38°C
T	+18°C to +43°C

- The refrigerant circuit has been tested for leaks.
- The appliance complies with current safety regulations and EC directives 73/23/EEC and 89/336/EEC.

Notes on energy saving



- Ensure that there is adequate space around the appliance for ventilation and air extraction.
- Avoid keeping the door open for too long.
- Store food logically. Do not exceed the storage period specified.
- Keep all food properly packed and covered so as to avoid its frosting up on the outside.
- Always allow hot food to cool to room temperature before placing in the appliance.
- Defrost frozen food in the BioFresh compartment.
- Keep the appliance door shut in the event of a breakdown. This will delay the cold loss and will help to maintain the quality of the frozen food for longer.

Safety instructions and warnings

Disposal notes

The packaging is made of recyclable materials.



- Corrugated board/board
- EPS moulded parts
- Polythene sheets
- Polypropylene straps

- **Keep packaging materials away from children - polythene sheets and bags can cause suffocation!**
- Please return the packaging to an official collection point.

Your old appliance: This contains some reusable materials and should be disposed of properly - not simply with unsorted household refuse.



- Discarded appliances should be disabled: Remove the plug, cut through the connection cable and render the catch unusable so that children cannot become trapped inside.
- Ensure that the refrigerant circuit is not damaged when the appliance that is no longer needed is taken away for disposal.
- Details of the refrigerant can be found on the type plate.
- Appliances which are no longer needed must be disposed of in a professional and appropriate way, in accordance with the current local regulations and laws.

Technical safety

- To prevent injury or damage to the unit, the appliance should only be transported wrapped and set up by two people.
- The refrigerant R 600a is environmentally friendly but flammable.
- Do not damage the refrigerant circuit pipes. Splashes of refrigerant can harm your eyes or ignite.
- If refrigerant escapes, remove all naked flames or sources of ignition in the vicinity of the leak, disconnect the appliance from the mains and ventilate the area well.
- In the event that the appliance is damaged, contact the supplier immediately before connecting to the mains.
- To guarantee safe operation, ensure that the appliance is set up and connected as described in these operating instructions.
- Disconnect the appliance from the mains if any fault occurs. Pull out the plug (not by pulling on the mains cable) or switch off or remove the fuse.
- **Any repairs and work on the appliance should only be carried out by the customer service department, as unauthorised work could prove highly dangerous for the user.** The same applies to changing the mains power cable.



Safety during use

- Do not store explosives or sprays using combustible propellants such as butane, propane, pentane, etc. in the appliance. Electrical components might cause leak-ing gas to ignite. You can identify such sprays by the printed contents or a flame symbol.
- Only store high-percentage alcohol in tightly sealed, upright containers.
- Do not allow naked flames or ignition sources to enter the appliance.
- Do not use electrical appliances inside the appliance (e.g. steam cleaners, heaters, ice makers, etc.).
- Do not stand on the plinth, drawers or doors or use them to support anything else.
- This appliance is not intended for use by persons (including children) with reduced physical, sensory or mental capabilities or lack of experience and knowledge unless they have been given initial supervision or instruction concerning use of the appliance by a person responsible for their safety. Children should be supervised to ensure that they do not play with the appliance.
- Avoid prolonged skin contact with cold surfaces or chilled/frozen food. This could cause pain, numbness and frostbite. In the case of prolonged skin contact, protective measures should be taken, e.g. gloves should be worn.
- Do not eat ice-cream, particularly ice lollies or ice-cubes, immediately after taking them from the freezer compartment as there is a



risk of "burning" because of the very cold temperatures.

- Do not consume food which has been stored for too long, as it could cause food poisoning.

Setting up

- When setting up/fitting ensure that the refrigerant circuit pipes are not damaged.
- Standard EN 378 specifies that the room in which you install your appliance must have a volume of 1 m³ per 8 g of R 600a refrigerant used in the appliance, so as to avoid the formation of inflammable gas/air mixtures in the room where the appliance is located in the event of a leak in the refrigerant circuit. The quantity of refrigerant used in your appliance is indicated on the type plate on the inside of the appliance.
- Avoid positioning in direct sunlight or next to an oven, radiator or similar, in damp locations or near spraying water.
- Always position the appliance directly up against the wall.
- Once in position, use the 10 spanner provided to adjust the feet so that the appliance is level and does not wobble.
- **The ventilation grilles should not be obstructed. Always ensure that there is good ventilation and that the outward flowing air is able to escape.**
- Condensation may form on the outside of the refrigerator/freezer during periods of high humidity. Constant ventilation of the installation site is recommended. More information can be found in the installation and modification instructions.
- Do not place heat-emitting appliances, e.g. microwave oven, toaster, etc., on top of the refrigerator or freezer.
- Remove all transportation safety components.
 - Remove sticky tape or spacers* from shelves and insert shelves in the required position.
 - Remove all protective film: from the decorative trims, front walls and side walls*.

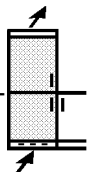

Connecting to the mains

Power supply (AC) and voltage

at the operating point must comply with the details on the type plate, which is located inside the appliance on the left, fig. A.

- **Connect the appliance with a properly earthed fused plug and socket only.**
- The socket must be fused with a 10 A fuse or higher, it must be away from the rear of the appliance and must be easily accessible.
- Do not
 - connect to stand-alone inverters,
 - operate with so-called energy-saving plugs - this can damage the electronic system,
 - connect to the supply with other equipment using an extension cable - risk of overheating.
- When removing the mains cable from the back of the appliance, remove the **cable holder** so as to avoid vibration noise.

The wires in the mains lead are coloured in accordance with the following code: green/yellow = earth, blue = neutral, brown = live. **Warning! This appliance must be earthed.**

Non-rewireable plugs BS 1363

If this machine or appliance is fitted with a non-rewireable plug, the following information applies: If the socket outlets are not suitable for the plug supplied with this product, it must be cut off and an appropriate plug fitted. The plug cut from the flexible cord should be disposed of and on no account be inserted into a 13 A socket elsewhere in the house (electric shock hazard). The fuse cover **must** be re-fitted when changing the fuse, and if the fuse cover is lost the plug **must not** be used until a suitable replacement is obtained. The colour of the correct replacement cover is that of the coloured insert in the base of the plug, or the colour that is embossed in words on the base of the plug (as applicable to the design of the plug fitted). The correct rating of the replacement fuses that are ASTA approved to BS 1362 should be fitted. Replacement fuse covers may be purchased from your local electrical suppliers, electricity showroom or approved service agent.

Operation and control elements

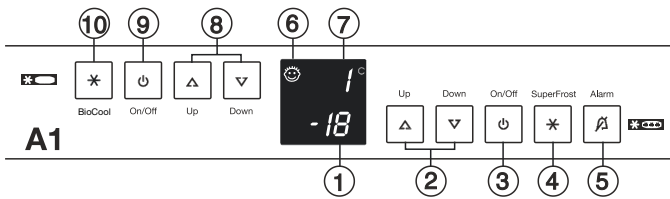

You are advised to clean the appliance before switching it on for the first time (see "Cleaning"). Switch on the appliance approx. 2 hours before loading it with frozen food for the first time. Do not load with frozen food until the temperature shows at least -18°C. The BioFresh ***○** and freezer *** ** *** compartments can be operated separately.

Switching the appliance on and off

- **To switch on:** Press the on/off buttons (9) on left for Bio-Fresh compartment and (3) on right for freezer compartment) so that the temperature displays light up or flash.
- **BioFresh compartment:** The interior light will light up when the door is open.
- **Freezer compartment:** When the appliance is switched on for the first time and while it is still warm, the freezer display will contain **dashes** until the temperature falls below 0°C.
- **To switch off:** Press the on/off buttons (9) on left for Bio-Fresh compartment and (3) on right for freezer compartment) for approx. one second so that the temperature displays go out.

Setting the temperature

The appliance is pre-set for normal operation. We recommend temperatures of +1°C in the BioFresh compartment and -18°C in the freezer compartment.

- **To reduce the temperature:** Press the **Down** button; (8) on left for BioFresh compartment and (2) on right for freezer compartment.
- **To increase the temperature:** Press the **Up** button.
- The temperature in the **BioFresh compartment** is controlled **automatically**, between 0°C and 3°C. If you require a higher or lower temperature, e.g. for storing fish, you can alter the temperature setting in the BioFresh compartment:
 - The setting range is displayed as between "**b 1**" and "**b 9**".
 - The default setting on delivery is "**b 5**".
 - The temperature can be changed by **± 5 increments**, displayed in the temperature display.

Note: By decreasing the temperature, "b4" to "b1", minus temperatures can be reached and the food will freeze slightly.
- For the **freezer compartment**, the setting range is displayed as between -14°C and -28°C. Whether you can obtain the lowest freezer temperature depends on where the appliance is positioned (if it is located in an area with a high ambient temperature it will not reach the lowest temperature).
 - While you are entering the temperature, the **set temperature will flash** on the display.
 - When you press the temperature setting buttons for the first time, the **most recent setting** is displayed.
 - You can change the settings in increments by briefly

pressing the buttons again. If the buttons are held down the temperature setting will change faster.

- Approximately 5 seconds after the button has been released, the display will automatically show the **actual** freezing or BioFresh temperature (known as the "**actual setting**").
- The altered temperature adjusts slowly to the new value.

Temperature display

In normal operation, the following settings will be displayed:

- the **average BioFresh temperature** in display (7) and
- the **warmest frozen food temperature** in display (1).

The display will flash:

- if you change the temperature or
- if the temperature rises by several degrees, indicating cold loss, e.g. if you place fresh, "warm" food in the freezer or if you remove or re-pack frozen food the temperature may rise for a short time due to warm air flowing into the freezer. Once you have finished loading or re-packing, the electronics will automatically re-set the temperature to the most recent setting. Short-term rises in temperature will not affect the frozen food.
- If "**F 0**" to "**F 5**" appears in the display, the appliance has a fault. Consult the customer service department indicating the fault number displayed as this will tell the technician what kind of irregularity has occurred.

Audible warning signal

The audible warning signal helps to protect frozen food and to save energy.

- **The audible warning device is switched off** by pressing the audible warning on/off button (5).
- It switches off automatically as soon as the temperature is low enough or
- the door is closed.

Audible door alarm (for BioFresh and freezer compartments)

- This sounds when the door has been left open for longer than about 180 seconds. The sound switch-off function is active as long as the door is left open. The alarm automatically switches back to standby when the door is shut.

Audible/visual temperature alarm (for the freezer compartment)

- It always sounds if the freezer temperature is not low enough (dependent on the temperature setting).
- The **temperature display flashes** at the same time.

This can be caused by:

- warm, fresh food being placed in the freezer,
- too much warm air from the outside entering when rearranging or removing frozen food.

The temperature display will continue to **flash** until the cause of the alarm has been rectified. It will then stop flashing and light up continually. The audible warning signal is now automatically **reset**.

Operation and control elements

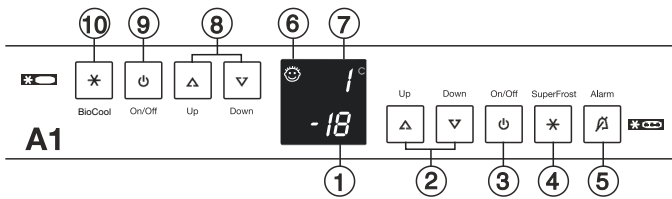

BioCool

The BioCool button switches the BioFresh compartment to maximum cooling. It is recommended particularly if you wish to cool **large** quantities of food, freshly baked cakes or meals rapidly.

- **Switching on:** Press the BioCool button (10) briefly so that it lights up.

Note: The BioCool function uses slightly more energy. After approx. 6 hours, however, the electronic control system switches back **automatically** to normal energy-saving operation.

If required, the BioCool function can be switched off sooner.

- **Switching off:** Press the BioCool button again until it goes out.

SuperFrost

Fresh food should be frozen to the core as rapidly as possible. Frozen food can also be given a cold boost. This is provided by the SuperFrost facility (4) and ensures that the nutritional value, appearance and flavour of the food remain intact.

- The maximum amount of food which can be frozen in 24 hours is shown on the type plate ("Freezing capacity ... kg/24h"), fig. A3, pos. (4). This amount varies according to the model and climate rating.

See "Freezing with SuperFrost" for more information.

Power failure/FrostControl display

If **nH** appears in the display, this means that the freezer temperature has risen too **high** during the last few hours or days due to a power failure.



- If you press the audible warning on/off button (5) whilst the display is reading **nH**, the **highest** temperature registered during the power failure will be displayed. Check the quality of the food and its suitability for consumption in case it has become too warm or even de-frosted.

- The highest temperature will appear for approx. 1 minute. After that, the actual temperature in the freezer will re-appear. The "highest temperature" display can be switched off by pressing the audible warning on/off button.

Once the power is re-instated, the appliance will continue to operate at the most recent temperature setting.

Additional functions

In set-up mode you can set the **child-proof lock** and adjust the **brightness of the display**.*

Activating set-up mode:

- Press SuperFrost button for approx. 5 secs - the SuperFrost button flashes - the display shows **c** for child-proof lock. Note: the value to be altered flashes.
- Select the required function by pressing the Up/Down button:

c = child-proof lock or **h = brightness.**

- Now select/acknowledge function by pressing SuperFrost button briefly:

- For **c = child-proof lock**, press the Up/Down button to select **c1 = child-proof lock on** or **c0 = child-proof lock off** and acknowledge with the SuperFrost button. When the symbol (6) is lit, the child-proof lock is activated.



- For **h = brightness**, press Up/Down button to select **h1 = minimum** to **h5 = maximum** brightness and acknowledge with the SuperFrost button.



Exit set-up mode:

- To exit the set-up mode, press the On/Off button; after 2 mins. the electronic system switches over automatically.
- The normal operating mode is activated again.

Interior light

This switches off automatically after the door has been opened for approx. 15 minutes. If it does not switch on when the door is opened briefly, but the temperature display is working, the bulb may be defective.

Replacing the bulb:

- **Bulb data:** max. 25 W; current and voltage must agree with the details on the type plate. Only use bulbs of the same size. Bulb fitting: E 14.
- Switch off the appliance. **Disconnect from the mains or remove or unscrew the fuse.**
- Press the light cover together at the sides as in fig. F1 (1). Lift it out and unclip at back (2).
- Replace the bulb as in fig. F2. To counteract the friction of the lock washer, turn the bulb with slightly more pressure. When inserting the new bulb, ensure that the lock washer is properly in place in the lamp socket.
- Clip the back end of the cover in and clip the sides into place.

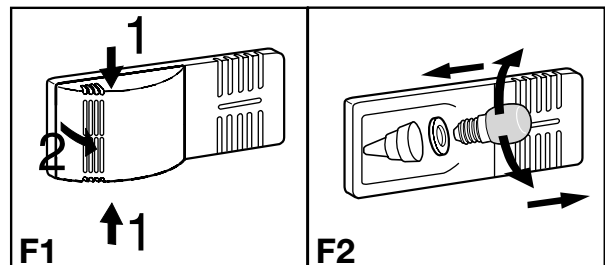

BioFresh compartment

The BioFresh compartment enables you to keep a range of **fresh food** fresh for up to three times as long as you would in a standard refrigerator, thus making your stocks last longer. Taste, freshness and nutritional value (vitamin B and C group content) remain largely intact. Spoilage and weight loss in vegetables and fruit are reduced, leaving food more fresh and natural.

The automatically controlled storage temperature, which is kept between 0°C and 2°C, and the resultant humidity provide the ideal storage conditions for different types of food.

The top drawer

is suitable for storing **dry and wrapped** food (e.g. dairy products, meat, fish, cold meats). The storage climate in this drawer is relatively **dry**.

The drawer with humidity control

can be set to "humid" for storage of unwrapped salad, vegetables and fruit. When the drawer is full, the climate will be "dew-fresh", with approximately 90% humidity.

You can set the humidity in this drawer to dry or moist **as required**.

Humidity selection, fig. A2:

- **"dry" setting: small humidity symbol** - slide control to left. Insert food that is suitable for being stored in a dry climate.
- **"humid" setting: high relative humidity of max. 90%, large humidity symbol** - slide control to right. This setting is suitable for storing unwrapped food with a high moisture content such as fresh lettuce.

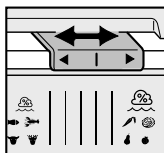

Notes:

- The humidity in the compartment depends on the moisture content of the food in it, and the frequency with which the compartment is opened.
- When buying food, check that it is fresh - the fresher the product and the higher its quality, the longer it will keep.
- Unwrapped animal and vegetable foods should be stored separately in the drawers. If there is not enough space for them to be stored separately, make sure that they are wrapped. Do not allow different types of meat to come into contact with one another but keep them packaged separately so as to avoid premature bacterial spoilage.
- Please note that protein-rich food spoils more quickly, i.e. crustaceans and shellfish spoil faster than fish, and fish faster than meat.
- Remove food from the drawers some time before consumption. Enjoyment will be enhanced in this way as the aroma and flavour develop best at room temperature.
- If you require space for large bottles and containers, - lift the **front half** of the split glass shelf* and carefully slide it under the back half until the stops click into the recesses, see figure.

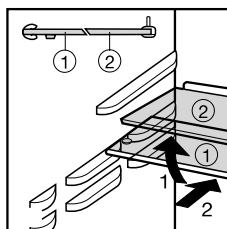

Storage times

for food in the BioFresh compartment:



Dry setting

butter	up to	30 days
cheese, soft	up to	30 days
milk, fresh	up to	7 days
sausage, cold cuts	up to	7 days
fish	up to	4 days
shellfish	up to	3 days
poultry	up to	5 days
pork		
large portions	up to	7 days
cut up	up to	5 days
beef	up to	7 days
game	up to	7 days

Humid setting

Vegetables, salad

artichokes	up to	21 days
asparagus	up to	14 days
broccoli	up to	14 days
Brussels sprouts	up to	30 days
cabbage	up to	180 days
carrots	up to	150 days
cauliflower	up to	21 days
celery	up to	30 days
chicory	up to	30 days
Chinese cabbage	up to	14 days
curly kale	up to	14 days
fennel	up to	21 days
garlic	up to	180 days
green onions	up to	7 days
herbs	up to	30 days
iceberg salad, endives,		
lamb's lettuce	up to	21 days
kohlrabi	up to	14 days
leeks	up to	60 days
lettuce	up to	10 days
mushrooms	up to	7 days
peas	up to	10 days
radicchio	up to	21 days
radishes	up to	14 days
savoy cabbage	up to	60 days
spinach	up to	7 days



Fruit

apples	up to	180 days
apricots	up to	14 days
bilberries	up to	14 days
blackberries	up to	8 days
cherries	up to	14 days
black and red		
currants	up to	21 days
dates (fresh)	up to	60 days
figs (fresh)	up to	7 days
gooseberries	up to	21 days
grapes	up to	90 days
kiwi fruits	up to	120 days
peaches	up to	30 days
pears	up to	120 days
plums	up to	21 days
quinces	up to	90 days
raspberries	up to	5 days
rhubarb	up to	21 days
strawberries	up to	5 days

The following products should **not** be stored in the BioFresh compartment: cold-sensitive vegetables such as cucumber, peppers, aubergines, avocados, semi-ripe tomatoes, beans, zucchini, and all cold-sensitive tropical fruits.

GB

Freezer compartment

Freezing with SuperFrost

SuperFrost



- Press the SuperFrost button ④ briefly so that it lights up. The freezer temperature will decrease and the appliance will switch to the lowest temperature.
- For small amounts of frozen food, it is normally sufficient to switch on SuperFrost 6 hours beforehand. For the **maximum** amount (see freezing capacity on the type plate) you will need to switch it on 24 hours beforehand.
- Then place the fresh food inside the freezer, preferably in the top drawers. If freezing the **maximum** quantity of food, do not use the drawers; instead, place the wrapped food directly on the shelves. Once the food is frozen you can load it into the drawers.
- The SuperFrost function switches off **automatically**. Depending on the quantity of food placed in the freezer, this will normally be between 30 and max. 65 hours. The freezing process is now complete, the **SuperFrost button will go dark**, and the freezer will switch back to normal energy-saving operation.

- **Removing drawers**, fig. G1: pull forward until the drawer stops and lift out.
- **Removing the shelf**, fig. G2: lift the shelf up at the front and pull out.

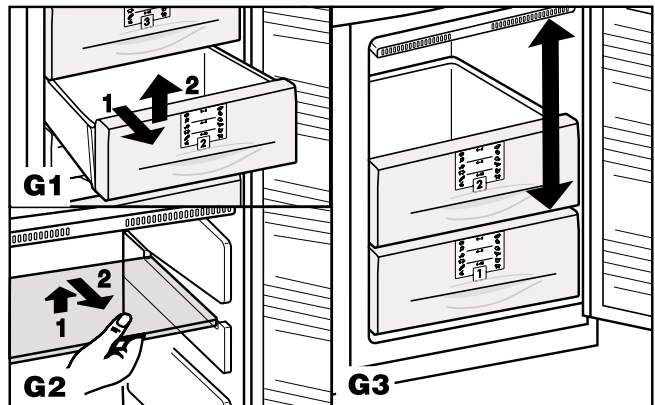

Note: You should **not** switch on the SuperFrost function:

- when placing frozen food in the freezer;
- when freezing up to approx. 2 kg fresh food daily.

Notes on freezing and storage

- **Items suitable for freezing:** meat, game, poultry, fresh fish, vegetables, fruit, dairy products, bread, baked goods, pre-cooked meals.

Not suitable: lettuce, radishes, grapes, whole apples and pears, fatty meat.

- **Pack frozen food** in standard freezer bags or reusable plastic, metal or aluminium containers.
- Do not allow fresh food which is to be frozen to come into contact with food already frozen. Always keep packs dry in order to avoid them sticking together.
- Always write the date and contents on the pack and do not exceed the stated storage time for the food. This prevents any risk of quality impairment.
- Pack food which you are freezing yourself in quantities appropriate to your household. To ensure that the food freezes right through quickly, the following quantities should not be exceeded per package:
 - fruit, vegetables: up to 1 kg;
 - meat: up to 2.5 kg.
- Blanch **vegetables** after washing and cutting them. (Add to boiling water for 2-3 minutes, remove and quickly cool down in cold water. If you blanch with a steamer or microwave oven, please observe the relevant operating instructions.)
- Do not salt or season fresh food or blanched vegetables before freezing. Only lightly salt and season other food. Some spices can alter their flavour intensity.
- Do not freeze bottles and cans which contain carbonated drinks as they might burst. Drinks can be cooled down quickly, but take the bottles out of the freezer compartment after an hour at the most.

- **Storage:** Each drawer and shelf can take **up to 25 kg** frozen food.

- **VarioSpace:** By removing a drawer and a shelf, you obtain the storage space for bulky goods equivalent to two drawer heights. Poultry, meat, large game pieces and tall baked goods can be frozen whole and further prepared in one piece.

- If you want to use the maximum net capacity, you can remove the drawers and store items directly on the shelves.
- **Always** leave the bottom drawer in the appliance.
- If you have removed the top drawer, **do not** cover the fan slits at the back, otherwise the freezer will not work properly.

To insert: proceed in reverse order, simply push shelf in as far as it will go.

- Always store identical food items together to avoid the door being open for unnecessarily long periods and to save energy.
- Do not exceed storage times given.

- **Thawing:** Only take out as much food as is immediately required for thawing. Cook food which has been thawed as quickly as possible.

Frozen food can be thawed in the following ways:

- in a conventional or fan oven
- in a microwave oven
- at room temperature
- in the refrigerator: the cold given off by the frozen food is used for cooling the other food.
- Flat portions of meat or fish can be cooked when partially thawed.
- Vegetables can be cooked from frozen (in half the normal time).

Information system*

Use frozen food within the recommended period.

The numbers between the symbols indicate the storage period in months for different kinds of frozen foods.

Storage times given are guide times for food frozen at home. Whether or not the lower or upper value is applicable depends on the food quality and how it was processed prior to freezing. The lower values always apply to food with a high fat content.

pre-cooked meals
ice-cream
fish
pork
vegetables
fruit

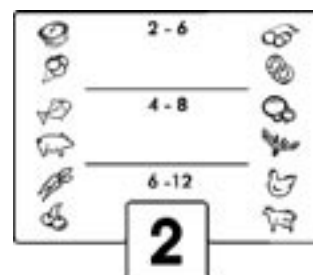

sausages
bread
mushrooms
game
poultry
beef/veal

Freezer compartment

Freezer tray*

This is used for gently freezing berries, herbs, vegetables and other small items and prevents them from sticking together. Items being frozen will largely retain their shape, and it will be easier to remove exactly the right quantity later on.

- Spread the items out loosely on the tray.
- Suspend the freezer tray in one of the top drawers. Freeze for 10 to 12 hours, then transfer to a freezer bag or container and put in a drawer.
- To defrost, spread the frozen items out loosely.

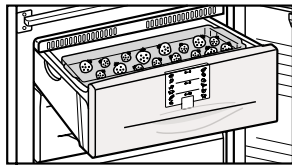

Cold-storage accumulators*

These prevent the temperature in the freezer from rising too quickly in the event of a power failure, thus preserving the quality of the food.

- To save space, you can freeze and store the cold-storage accumulators in the freezer tray.
- To ensure maximum storage time in the event of a power failure, place the **frozen** cold-storage accumulators in the top freezer drawer on top of the food.

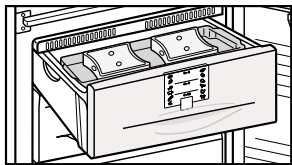

Making ice-cubes*

- Fill the ice-cube tray with water.
- Place the ice-cube tray in the appliance and leave it to freeze.
- The ice-cubes can be removed from the tray by twisting or by holding upside down for a short time under running water.

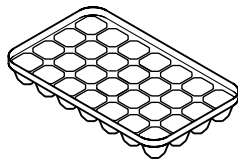

Cleaning

Notes on defrosting

The NoFrost system **automatically** defrosts the appliance.

In the BioFresh compartment

The water is evaporated by the heat from the compressor; drops of water on the rear wall are perfectly normal.

- Simply ensure that the defrost water can flow freely through the drain hole in the rear wall (arrow in fig. A).

In the freezer compartment

Any moisture arising collects on the evaporator and freezes, and is periodically defrosted and evaporated.

The automatic defrosting system keeps the freezer frost-free and eliminates the time and effort spent on defrosting manually.

Cleaning

- **Before cleaning, always switch off the appliance. Disconnect from the mains or unscrew or remove the fuse.**
- Clean the outer walls, inside and equipment by hand with lukewarm water and a little detergent. Because of the risk of injury and damage to the appliance, steam cleaning equipment should not be used.
- We recommend using a soft cloth and an all-purpose clean-



Cleaning

er with a neutral pH value. Only use food compatible cleaning and care agents on the inside of the appliance.

- Use a commercially available stainless-steel cleaning agent for stainless-steel appliances*.
- In order to achieve best possible protection, apply a stainless-steel care agent uniformly in grinding direction after cleaning. Points which are darker at the start and a more intensive coloration of the stainless-steel surface are normal.
- Do not use abrasive sponges or scourers, do not use concentrated cleaning agents and never use cleaning agents containing sand, chloride or acid or chemical solvents, as these would damage the surfaces and could cause corrosion.
- Do not allow cleaning water to run down the drain gully or to penetrate the ventilation grilles or electrical components. Dry the appliance.
- Remove the protective film from the decorative trims*.
- Do not damage or remove the type plate on the inside of the appliance. It is very important for servicing purposes.

● To clean the storage shelves:

- lift the shelves, slide forwards and remove. Always insert shelves with the guard bar at the back pointing upwards, otherwise food may freeze onto the rear wall.
- The glass shelves are fitted with stops to prevent them being pulled out accidentally.

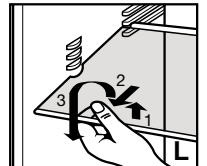

- To clean the **BioFresh drawers**, pull the drawers right out, grip at back and lift out (fig. M1).

- To re-insert: place the drawers on the extended rails - the rails must align with the front of the drawer - and slide in (fig. M2).

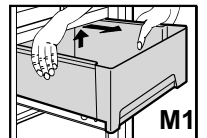

- Simply pull the **drawer cover** out towards you. When re-inserting, make sure the bearing pins snap into place in the grooves.

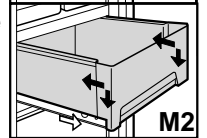

The drawer and the cover must be flush with one another vertically.

- Clean the **drain hole** in the rear wall frequently, fig. N, arrow. **If necessary, clean with a thin object, e.g. a cotton swab or similar.**

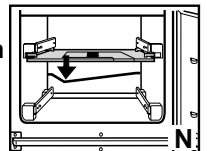

- The dust should be removed from the **refrigeration unit** and heat exchanger - metal grid at the back of the appliance - once a year. Dust deposits increase energy consumption.

- Ensure that none of the wires or other components are dislodged, bent or damaged.

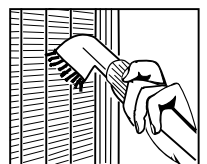

- Then connect/switch on the appliance and start to insert the food to be frozen as the temperature drops.

If the appliance is to be **left switched off for any length of time**, empty the appliance, disconnect from the mains, clean as described above and leave the door open so as to avoid odours.

Troubleshooting

Your appliance is designed and manufactured for a long life span and reliable operation.

If a malfunction nonetheless occurs during operation, check whether it is due to an operating error. Please note that even during the warranty period the resultant servicing costs in this case will have to be borne by the owner.

You may be able to rectify the following faults by checking the possible causes yourself:

Malfunction Possible cause and remedy

Appliance does not work, display is off

- Is the appliance switched on properly?
- Is the mains plug properly inserted in the socket?
- Is the socket fuse intact?

The interior light does not come on

- Is the BioFresh compartment switched on?
- Has the door been open for more than 15 minutes?
- The bulb is defective. Change the bulb as described in "Interior light".

Loud running noise

- Is the appliance standing firmly on the floor, or does the compressor cause nearby items of furniture or objects to vibrate? If necessary, move the appliance slightly, align by adjusting the adjustable feet, or move bottles and containers apart.

- **Burbling noises** are normal. These are caused by the refrigerant flowing round the refrigerant circuit.

A short **clicking sound**: This will be heard whenever the refrigeration unit (the motor) switches on or off automatically.

Motor noise: This will be slightly louder for a brief period when the refrigeration unit switches on. The refrigerating capacity will increase when the SuperFrost function is activated, fresh food has just been placed in the appliance or the door has been left open for a while.

The audible warning signal sounds, the temperature is not cold enough

- Have you put too much fresh food into the freezer **without** activating SuperFrost? (See "SuperFrost")
- Does the door close properly?
- Is the appliance sufficiently well ventilated? Clear ventilation grilles if necessary.
- Is the ambient temperature too hot? (See "Safety regulations")
- Has the appliance been opened too often or left open too long?
- If applicable, wait until the appliance reaches the required temperature itself.

nF appears in the display

- There has been a power failure; proceed as described in "Power failure/FrostControl display".

The outside of the appliance may feel warm in places

- That is quite normal. The heat from the cooling circuit is used to avoid the formation of condensate.

Customer service and type plate

If none of the above causes apply and you cannot rectify the fault yourself, or if the temperature display reads "F 0" to "F 5", this means that there is a fault. Please contact your nearest customer service department (see enclosed list for addresses). Give the **fault number displayed**, together with the

type designation ①, **service number** ② and **appliance number** ③

as given on the type plate, so as to ensure rapid, accurate servicing. The type plate is located inside the appliance on the left-hand side.

Leave the appliance shut until the customer service engineer arrives so as to prevent any further cold loss.

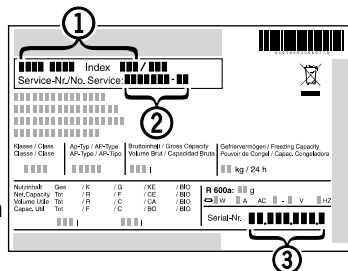

Instructions for installation and modification

Installation instructions:

- Do not install the appliance directly next to another refrigerator or freezer. This is important to prevent condensation and consequential damage resulting from it.
- This does not apply to Side-by-Side models (SBS). They are designed for Side-by-Side installation with another refrigerator/freezer. The "Installation instructions for Side-by-Side combinations" are supplied in the accessories bag for the SBS freezer or the appliance with a freezer compartment.

Installation dimensions

For the **external dimensions** of the appliance, see fig. S.

Changing over door hinges

On appliances which are intended for individual installation the door hinges can be changed from one side to the other. On SBS appliances in stainless steel finish, which are designed for Side-by-Side installation, the door hinges **must not** be transferred to the other side!

- Only change over door hinges when mains plug is disconnected!
- Fig. T. With the door open, lever out plinth panel ① on the hinge side with a screwdriver and remove from front.
- Lever out cover ② with a screwdriver. Close door.
- Unscrew screw M5 ③.
- Pull hinge component ④ with hinge pin ⑤ out from underneath and remove.
- Open door, lift out at bottom and remove.
- Pull middle hinge pin ⑥ out from underneath.
- Tilt out top door and lift off from underneath (with version I, do not lose spacer sleeve ⑨).
- Transfer all hinge components onto the other side:
- Top: depending on version, proceed as follows:

Version I (visible operating panel): Lever out covers ⑧ with a screwdriver at the front and remove at an angle from below. Remove hinge pin ⑦ and insert on the opposite side. Use the hexagon socket on the open-ended spanner provided (spanner width 5). Fit covers ⑧ again: insert at rear and click into place at front.

Version II (concealed operating panel): Lift up cover ⑧ on handle side, push outwards; lift up cover on hinge side and pull off.

- Unscrew earthing plate ⑩: first earthing screw ⑩, then inner retaining screw ⑪.
- Unscrew hinge ⑨: first undo earthing screw ⑩, then retaining screws ⑪. Fit hinge ⑨ to opposite side: for easy assembly, fit hinge from above and first tighten with the upper retaining screw ⑪ M5, then screw ⑪ and finally earthing screw ⑩ M4.
- Turn earthing plate ⑩ through 180° and screw tight again on the new handle side: first retaining screw ⑪, then earthing screw ⑩.
- Insert hinge pin ⑦ in the other retaining hole. Use the hexagon socket on the open-ended spanner provided (spanner width 5).
- Fit covers ⑧ again: insert hinge-side cover by sliding outwards and click into position; insert handle-side cover by sliding inwards and click into position.
- Centre: Change over cover ⑩ with hinge ⑩: unscrew screws, lift off cover ⑩ and hinge ⑩ to the side, turn through 180° and replace on the other side, remove hinge bushing ⑫ and re-insert from top.
- Bottom: Using a screwdriver, remove the spacer ⑬ and replace on the other side.

Instructions for installation and modification

- Re-attach the doors: Remove plugs (14) from the door mounting points and re-place on the other side.
 - Suspend top door in hinge pin (7) (with version I, do not forget to use spacer sleeve (9)), close door.
 - Slide middle hinge pin (6) into the door mounting from below through the hinge (11). Make sure the door is flush with the body of the appliance; adjust if necessary using the slots on the hinge.
 - Suspend lower door, close.
 - Rotate hinge component (4) by 180°, remove hinge pin (5), turn by 180° and replace, mind the locking facility. Mount both parts in the hinge (15): slide the pin into the door mounting through the hinge, tilt in the hinge component, slide up and attach with screw (3).
 - Align the door flush with the body of the appliance using the slot on the hinge (15), then tighten screw (3).
 - Attach the plinth panel (1) and click into place by pressing.
 - With the door open, insert the cover (2) in the plinth panel at the front and click into place at the back.
 - Transfer* door handles (16) and plugs (13). With the door open, carefully lift out the pressure plates* (17) at the front and slide away; unscrew handle using a Torx® or Phillips screwdriver*.
- Re-assemble in reverse order: replace the pressure plates and click into position.

Insertion into row of kitchen units

Fig. U. The appliance can be installed in a row of kitchen units. To adapt the height of the appliance to the surrounding furniture a top unit (1) can be added.

A gap of at least 50 mm depth must be provided behind and along the entire width of this unit so as to ensure sufficient ventilation. The area of ventilation underneath the ceiling should be at least 300 cm². The greater the area the more economically the appliance will run.

- When installing with standard kitchen units (max. depth 580 mm), the appliance can be set up right next to the kitchen unit. The door protrudes 34 mm from the side of the kitchen unit and 51 mm at the front. This enables it to be opened and closed without difficulty.
- When setting up the appliance next to a wall (4), a minimum distance of 36 mm must be provided on the hinge side between the appliance and the wall (for the handle when the door is open).

- ① top unit
- ② refrigerator/freezer
- ③ kitchen unit side panel
- ④ wall

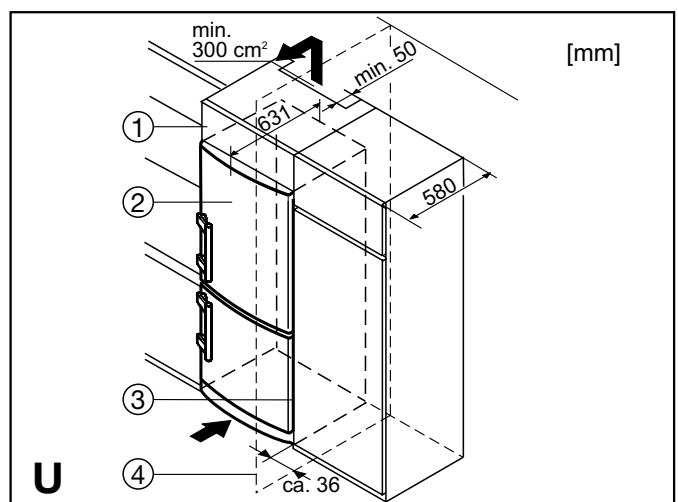
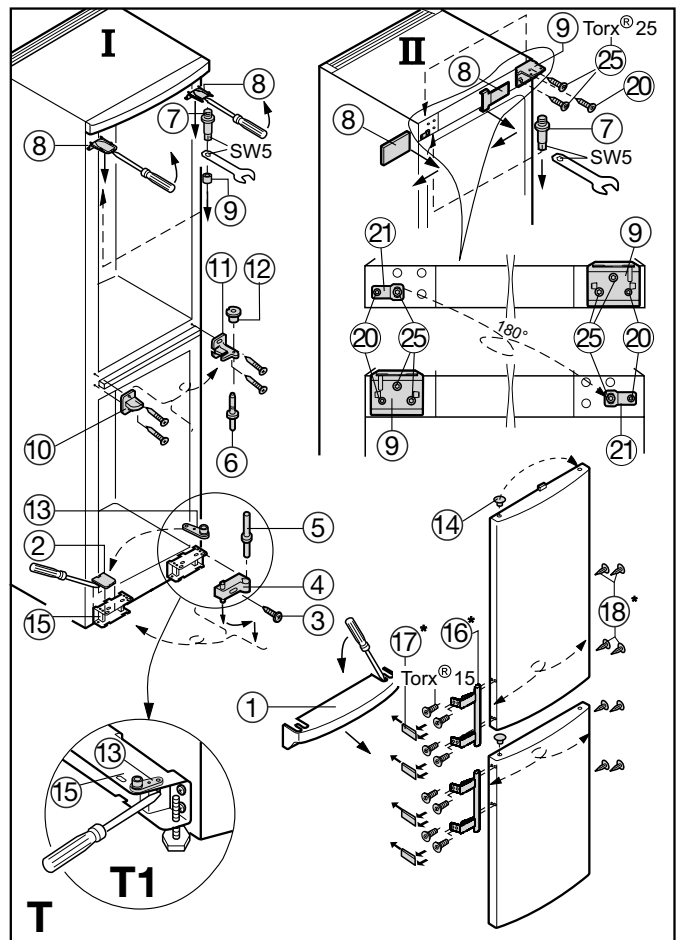
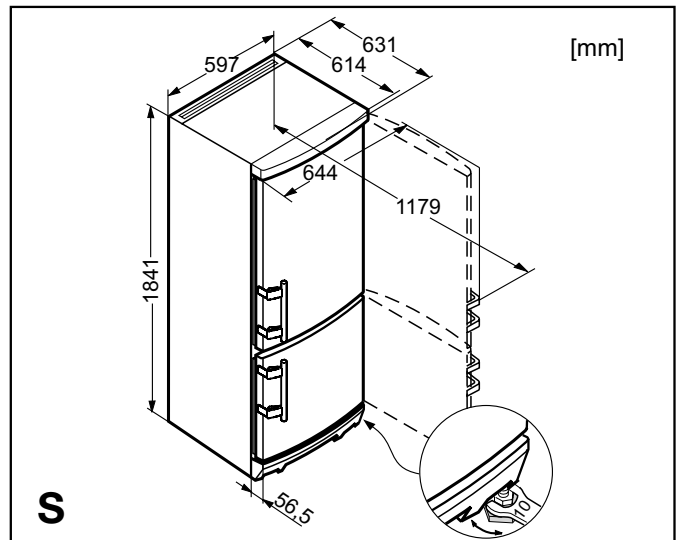

All types and models are subject to continuous improvement and the manufacturer therefore reserves the right to make modifications in the shape, equipment and technology.